

LIMITED ONE YEAR WARRANTY

Warranty Coverage: This product is warranted to be free from defects in materials or workmanship for a period of one (1) year from the original purchase date. This product warranty is extended only to the original consumer purchaser of the product and is not transferable. For a period of one (1) year from the date of original purchase of the product, our Repair Center will, at its option, either (1) repair the product or (2) replace the product with a reconditioned comparable model. These remedies are the purchaser's exclusive remedies under this warranty.

Warranty Service: To obtain warranty service, you must call our warranty service number at 1-800-233-9054 for return instructions on how to deliver the product, in either the original packaging or packaging affording an equal degree of protection to the Repair Center specified below. You must enclose a copy of your sales receipt or other proof of purchase to demonstrate eligibility for warranty coverage.

To return the appliance, ship to:

ATTN: Repair Center
708 South Missouri Street
Macon, MO 63552 USA

To contact us, please write to, call, or email:

Consumer Relations Department
PO Box 7366
Columbia MO 65205-7366 USA
1-800-233-9054
E-mail:
consumer_relations@toastmaster.com

What Is Not Covered: This warranty does not cover damage resulting from misuse, accident, commercial use, improper service or any other damage caused by anything other than defects in material or workmanship during ordinary consumer use. This warranty is invalid if the serial number has been altered or removed from the product. This warranty is valid only in the United States and Canada.

LIMITATION ON DAMAGES: THERE SHALL BE NO LIABILITY FOR ANY INCIDENTAL OR CONSEQUENTIAL DAMAGES FOR BREACH OF ANY EXPRESS OR IMPLIED WARRANTY OR CONDITION ON THIS PRODUCT.

DURATION OF IMPLIED WARRANTIES: EXCEPT TO THE EXTENT PROHIBITED BY APPLICABLE LAW, ALL IMPLIED WARRANTIES AND CONDITIONS, INCLUDING, WITHOUT LIMITATION, IMPLIED WARRANTIES AND CONDITIONS OF MERCHANTABILITY AND FITNESS FOR A PARTICULAR PURPOSE OR USE ON THIS PRODUCT ARE LIMITED IN DURATION TO THE DURATION OF THIS WARRANTY.

Some jurisdictions do not allow the exclusion or limitation of incidental or consequential damages, or allow limitations on how long an implied warranty lasts, so the above limitations or exclusions may not apply to you. This warranty gives you specific legal rights and you may have other rights under the laws of your jurisdiction.

For more information on our products, visit our website: www.maxim-toastmaster.com.

Made in China

OWNER'S MANUAL

Model No. ICM15

Salton® Big Chill™

FROZEN DESSERT MAKER



TABLE OF CONTENTS

Important Safeguards	3
Additional Important Safeguards	4
Introduction	6
Getting to Know Your Big Chill™ Frozen Dessert Maker .	7
Before Using for the First Time	8
Operating Instructions	10
User Maintenance Instructions	14
Helpful Hints	14
Troubleshooting	16
Recipes	17
Warranty/Consumer Relations	back cover

IMPORTANT SAFEGUARDS

When using electrical appliances, basic safety precautions should always be followed including the following:

1. Read all instructions.
2. To protect against risk of electrical shock do not put cord, plugs, or appliance in water or other liquid.
3. Close supervision is necessary when any appliance is used by or near children.
4. Unplug from outlet when not in use, before putting on or taking off parts, and before cleaning.
5. Do not operate any appliance with a damaged cord or plug or after the appliance malfunctions, or is dropped or damaged in any manner. Contact Consumer Service for examination, repair or electrical or mechanical adjustment.
6. The use of attachments not recommended or sold by the manufacturer may cause fire, electric shock or injury.
7. Do not use outdoors.
8. Do not let cord hang over edge of table or counter.
9. Do not let cord contact hot surface, including the stove.
10. The Frozen Dessert Maker must **NEVER** be laid on its side or turned upside down.
11. Use the Frozen Dessert Maker away from heat sources. Keep it at a distance of at least 3/4 inch from walls or other objects that could obstruct free air circulation.
12. Avoid contact with moving parts. Keep hands and utensils out of Mixing Cylinder while in use to reduce risk of injury to persons or the Frozen Dessert Maker. **Do not use sharp objects or utensils inside the Mixing Cylinder!** Sharp objects will scratch and damage the inside of the cylinder. The included Plastic Mixing Knife may be used when the unit is OFF.

SAVE THESE INSTRUCTIONS

For Household Use Only

ADDITIONAL IMPORTANT SAFEGUARDS

1. All users of this appliance must read and understand this Owner's Manual before operating or cleaning this appliance.
2. The cord to this appliance should be plugged into a 120V AC electrical outlet only.
3. Do not leave this appliance unattended during use.
4. If this appliance begins to malfunction during use, immediately turn the unit OFF and unplug the cord. Do not use or attempt to repair the malfunctioning appliance.
5. If this appliance falls or accidentally becomes immersed in water, unplug it immediately. Do not reach into the water! Do not use this appliance after it has fallen into or becomes immersed in water.
6. To reduce the risk of injury to persons or property, never use this appliance in an unstable position.
7. Do not use this appliance for other than its intended use.
8. The maximum continuous operation time of the Dasher Motor is 50 minutes. A 60 minute rest interval is required between 50 minute operating intervals of the Dasher Motor.

IMPORTANT: This unit contains a compressor for chilling purposes. During transportation and handling it is possible that the unit was turned on its side or upside down. The Refrigerant and Oil in the compressor must separate again before using. Allow the unit to sit correctly for 12 hours before using. This must be done anytime the unit has been on its side or upside down.

WARNING: To reduce the risk of personal injury, always unplug Frozen Treat Maker's Dasher Motor before inserting or removing Dasher.

GROUNDED 3-CONDUCTOR PLUG

This appliance is equipped with a grounded-type 3-wire cord (3-prong plug). This plug will only fit into an electrical outlet made for a 3-prong plug. This is a safety feature. If the plug should fail to fit the outlet, contact an electrician to replace the obsolete outlet. Do not attempt to defeat this safety feature.

SHORT CORD INSTRUCTIONS

A short power-supply cord is provided to reduce the risk resulting from becoming entangled in or tripping over a longer cord.

Do not use an extension cord with this product.

ELECTRIC POWER

If the electrical circuit is overloaded with other appliances, your appliance may not operate properly. It should be operated on a separate electrical circuit from other appliances.

PLASTICIZER WARNING

CAUTION: To prevent Plasticizers from migrating from the finish of the countertop or tabletop or other furniture, place **NON-PLASTIC** coasters or placemats between the appliance and the finish of the countertop or tabletop.

Failure to do so may cause the finish to darken, permanent blemishes may occur or stains can appear.

INTRODUCTION

Congratulations on the purchase of your Salton® BIG CHILL™ Frozen Dessert Maker!

Now with the BIG CHILL™ you can enjoy the freshest ice creams, sherbets, sorbets, frozen yogurts, slushies and frozen bar drinks unlike any you have ever enjoyed. Since you are preparing quantities that will be enjoyed soon after mixing you don't need to prepare the ingredients the same way as commercially made products. For instance, fruits can be used without cooking them and losing their fresh picked flavor. No preservatives are needed either.

The BIG CHILL™ produces ice cream and other frozen desserts utilizing its own compressor to chill your ingredients to the perfect temperature without the need or mess of salt and ice that most ice cream machines need. The Dasher Motor turns the ingredients effortlessly and the Electronic Timer lets you know when your desserts are ready to enjoy.

The BIG CHILL™ is designed with ease of use and easy cleanup so that making your own ice cream and frozen desserts is as much fun as eating them.

The following pages in this manual will familiarize you with the operation of the BIG CHILL™ Frozen Dessert Maker. Following the operating instructions you will find many recipes to get you started using the BIG CHILL™ to prepare some of your classic favorites and some new tastes to explore. After getting used to the BIG CHILL™ try your own recipes or look for many more that are available on the internet or in book stores.

Getting to Know Your BIG CHILL™ Frozen Dessert Maker

The box containing your Salton® Big Chill™ Frozen Dessert Maker should include the following parts. If any of the following are missing, contact consumer service:

PRODUCT MAY VARY SLIGHTLY FROM ILLUSTRATION

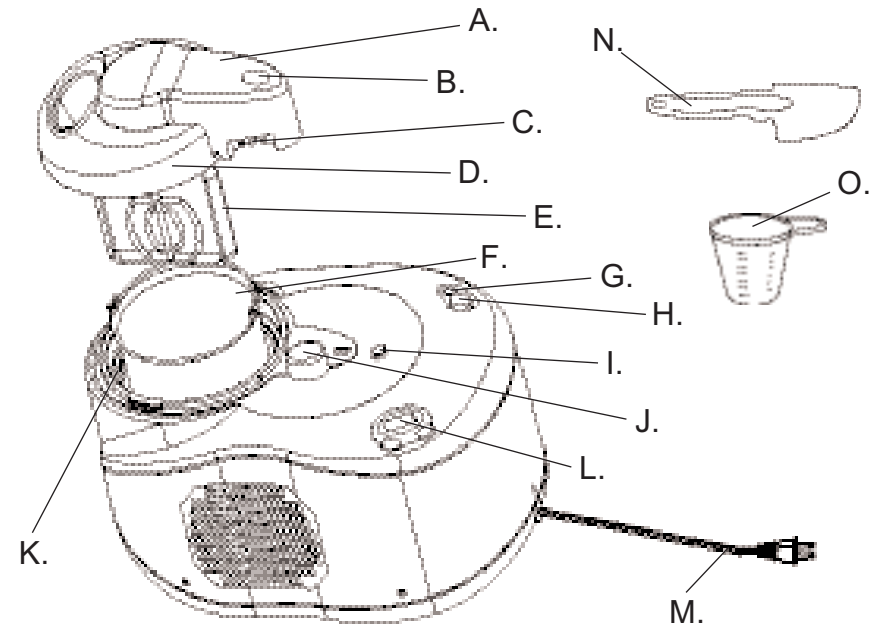

- | | |
|--|--|
| A. Dasher Motor (P/N 71129) | J. Dasher Motor Socket Connection Plug |
| B. Start/Stop Button for Dasher Motor | K. Fixed Stainless Steel Chilling Cylinder |
| C. Connection Plug of Dasher Motor | L. Electronic Timer LED and Controls |
| D. Transparent Cover (P/N 71130) | M. 3-Prong Power Cord |
| E. Removable Dasher (P/N 71131) | N. Plastic Mixing Knife (P/N 71133) |
| F. Removable Mixing Cylinder (P/N 71132) | O. Measuring Cup (P/N 71134) |
| G. Chilling System Indicator Light | P. Locknut (P/N 71135) (Not Shown, See Figure 2) |
| H. Chilling System On/Off Switch | |
| I. Dasher Motor Release Button | |

BEFORE USING FOR THE FIRST TIME

Carefully unpack and remove any packing materials and literature.

Before use, thoroughly wash all parts that will come into contact with the ice cream (including the Removable Cylinder, Dasher and Transparent Cover) with warm soapy water, rinse, and wipe dry with soft cloth. You may wipe the Fixed Stainless Steel Cylinder with a damp cloth but make sure it is completely dried before use.

Never immerse Motor Housing or Dasher Motor in water or any other liquid.

IMPORTANT: Place the Frozen Dessert Maker upright on a flat surface for at least 12 hours before using it for the first time, to allow the oil contained in the compressor to return to the compressor reservoir. Failure to do so before operation could cause permanent damage to the unit.

This procedure must be followed whenever the Frozen Dessert Maker has been placed in a non-upright position for any reason.

When your Frozen Dessert Maker is first used, you may experience an odor. This is normal. After the first few uses, this should no longer occur.

PREPARING THE FROZEN DESSERT MAKER

Before assembling the Frozen Dessert Maker, make sure the Start/Stop Button of the Dasher Motor is in the Stop position and the electric power cord is unplugged.

1. ADDING THE REMOVABLE CYLINDER

Insert the Removable Cylinder to the Fixed Stainless Steel Cylinder of the Frozen Dessert Maker's housing, until the Removable Cylinder is completely seated into position. (See Figure 1)

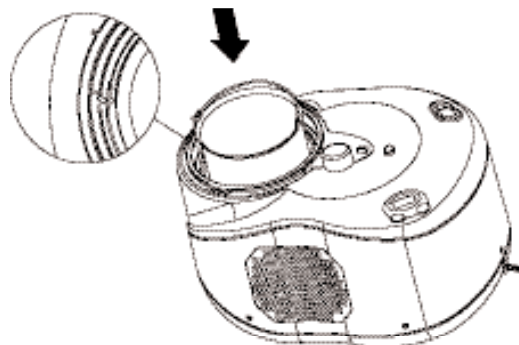

Figure 1

NOTE: The Removable Cylinder should NEVER be used in a conventional oven, microwave oven, on top of the range or on any other heated surface. If the Removable Cylinder is scratched or chipped or dented do not use. Do not add hot liquids to the Removable Cylinder.

2. ATTACHING THE TRANSPARENT COVER

Place the Transparent Cover into the bottom of the Dasher Motor and secure with the supplied locknut. (See Figure 2)

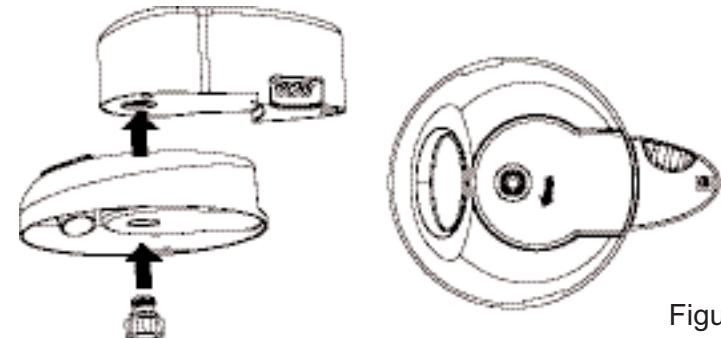

Figure 2

3. INSERTING THE DASHER

Make sure the Start/Stop Button of the Dasher Motor is in the Stop Position. When the button is depressed it is in the Start Position and when it is not it is in the Stop Position. Insert the Dasher into the Dasher Motor Socket, until the Dasher snaps into position. (See Figure 3)

WARNING: To reduce the risk of personal injury, always unplug Frozen Treat Maker's Dasher Motor before inserting or removing Dasher.

NOTE: It is important that the Dasher be inserted properly into the Dasher Motor Socket. Installing the Dasher any other way will result in an incorrect mixing action.

NOTE: Do not use any Dasher other than the one provided (P/N 71131).

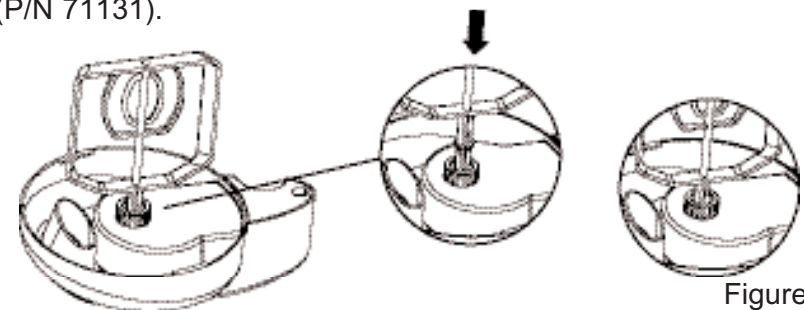

Figure 3

PREPARING THE FROZEN DESSERT MAKER cont'd...

4. INSTALLING THE DASHER MOTOR

Rotate Dasher Motor clockwise until it locks into place (See Figure 4). When the Dasher Motor locks into place, the Connection Plug of the Dasher Motor will make a proper connection with the Dasher Motor Connection Plug Receptacle.

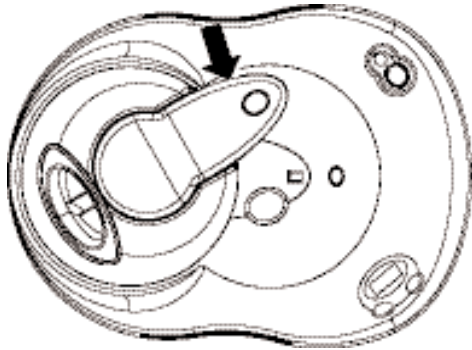

Figure 4

OPERATING INSTRUCTIONS

USING THE ELECTRONIC TIMER

The Electronic Timer built-in to your BIG CHILL™ Frozen Dessert Maker allows you to set the time to the 40 or 50 minutes that the Dasher Motor will run. Choose the time that corresponds to the recipe you are following. The Electronic Timer will switch off the Dasher Motor power at the end of the specified time and the buzzer will sound. If the ice cream has not achieved the desired thickness you may then reset the Electronic Timer to run for an additional 5 to 10 minutes.

NOTE: Do not overmix. Mixing too long can result in damage to the Dasher Motor, as the frozen dessert will begin to freeze too hard to be mixed further.

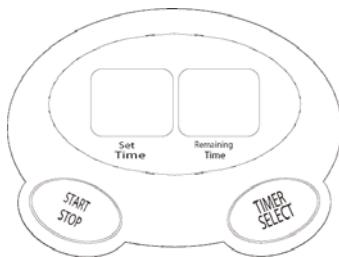

IMPORTANT

1. Plug the power cord into 120V AC outlet. The Electronic Timer LED will display Set Time on the left side, and on the right side the LED will flash to indicate the remaining time. There are two time options to choose from: 40 minutes or 50 minutes.
2. Press the Start button on the Electronic Timer control panel, and then press the power switch on the mixing assembly, the Dasher Motor will start working.
3. When the Electronic Timer reaches the last 30 seconds of the selected setting time, a buzzer will sound to notify you the selected setting time is almost completed. The Dasher Motor will automatically be switched off when time runs out.

MAKING FROZEN DESSERTS

Position the Frozen Dessert Maker near an electrical outlet on a flat stable surface, allowing adequate space around it, without obstructing the ventilation grills at the sides.

If you have not already done so make sure you have completed the steps in “Preparing The Frozen Dessert Maker” section earlier in this manual.

1. Plug the power cord into 120V AC outlet.
2. Start the Built-in Chilling System by pressing the On/Off Chilling Switch. The indicator LED will light to show that the Chilling System is operating. Allow five minutes before adding ingredients to the Removable Cylinder to allow both cylinders to reach the optimum temperature.
3. After five minutes have passed since turning on the Built-in Chilling System, turn on the Dasher Motor by pressing the Start/Stop Button on the Dasher Motor, then add the ingredients (according to the recipe) through the opening in the Transparent Cover. Ingredients should be at a refrigerated temperature. NEVER use hot ingredients.
4. Set the Electronic Timer according to the recipe. See “Using the Electronic Timer”.
5. Never fill the Removable Cylinder more than half full if using recipes not contained within this Owner’s Manual. Most frozen dessert recipes expand in volume during the last minutes of preparation and it will fill the cylinder.

OPERATING INSTRUCTIONS cont'd...

MAKING FROZEN DESSERTS cont'd...

6. During preparation, you can add chocolate chips, raisins and other ingredients through the opening in the Transparent Cover. Alcoholic beverages should not be added until the end of preparation, as they will slow the chilling process.
7. Preparation time may vary from 15 to 50 minutes, depending on the recipe as well as the quantity and temperature of the ingredients used.

IMPORTANT: Avoid turning off the Built-in Chilling System before the frozen dessert is ready. If the switch is turned off or in the event of power failure, the Built-in Chilling System automatically shuts down for approximately five minutes, which may impact the success of the ice cream or other frozen dessert.

8. When the frozen dessert has reached a good consistency, the Dasher Motor rotation reverses direction, indicating that the frozen dessert is ready. You may either shut off the Dasher Motor at this time and enjoy your Frozen Treat or you may wait for the Dasher Motor to automatically shut off when the Electronic Timer completes its countdown.
9. If you desire a slightly thicker frozen dessert, leave the Built-in Chilling System on for an extra 5 to 10 minutes.

IMPORTANT: After each operation, make sure the Dasher Motor and Built-in Chilling System are Off and allow the unit to sit for one hour, then additional desserts can be made if desired.

10. To aid in removing the frozen dessert, remove the Dasher Motor (including Transparent Cover and Dasher). Turn Off the Dasher Motor, turn Off the Built-in Chilling System and unplug the Ice Cream Maker. Press the Dasher Motor Release Button down and remove the Dasher Motor (including Transparent Cover and Dasher) by rotating counter clockwise.
11. Remove the frozen dessert from the Removable Cylinder using the plastic mixing knife (provided) or a wooden spoon. Do not use metal or sharp utensils, as they will damage the Removable Cylinder.
12. After removing the frozen dessert, allow the Removable Cylinder to reach room temperature, then rinse and wash with warm soapy water. Dry thoroughly with a soft cloth.

STORING FROZEN DESSERTS IN THE FROZEN DESSERT MAKER

Frozen desserts can be kept in the Frozen Dessert Maker for 10 to 20 minutes with the Dasher Motor off after mixing is completed. The Built-in Chilling System should be turned off after 10 minutes.

STORING FROZEN DESSERTS IN THE FREEZER

You can store your frozen desserts in your freezer for a limited time period; however keeping it too long will reduce its flavor and quality. After one to two weeks, any leftover frozen dessert should be disposed of properly.

To store frozen dessert in the freezer, follow these rules:

Store the frozen dessert in a clean, well-sealed freezer container. Do not use the Removable Cylinder as a storage container.

Maintain a minimum temperature of 27°F in your freezer.

Mark the date of preparation and type of frozen dessert on the container.

IMPORTANT

Frozen desserts are susceptible to bacteria. The Frozen Dessert Maker and tools must be kept clean and dry.

Never refreeze unfrozen or semi-frozen desserts.

Remove the frozen dessert container from the freezer about half an hour before serving and place it in the refrigerator to allow it to soften to a scoopable hardness.

Frozen desserts may also be set out for 10 to 15 minutes at room temperature to reach a suitable temperature for scooping. Keep the container closed.

DESSERT STORAGE TIMES IN FREEZER

Desserts made from raw ingredients:

1 week

Sorbets:

1 to 2 weeks

Desserts made from semi-cooked ingredients:

2 weeks

USER MAINTENANCE INSTRUCTIONS

CARE AND CLEANING

Before cleaning the Frozen Dessert Maker, make sure the Frozen Dessert Maker is unplugged.

To release the Transparent Cover from the Dasher Motor, loosen the locknut beneath the motor assembly (See Figure 1).

The Removable Cylinder, Dasher and Transparent Cover can be washed in warm water with dishwashing liquid.

The Fixed Cylinder may be wiped with a damp, soft cloth. Then dry thoroughly with a cloth.

Do not wash any of the components in a dishwasher.

The Dasher Motor assembly can be cleaned with a damp cloth.

Never immerse the Dasher Motor in water and do not rinse under the tap.

The Frozen Dessert Maker housing can be cleaned with a damp cloth.

Never immerse the Frozen Dessert Maker in water and do not rinse under the tap.

STORAGE

Unplug unit; store in its box or in a clean, dry place.

Never store it while it is still plugged in.

Never wrap cord tightly around the appliance.

Do not put any stress on the cord where it enters the unit, as it could cause the cord to fray and break.

HELPFUL HINTS

Certain recipes involve cooking. Prepare them at least a day ahead to ensure that they chill completely. It is recommended to always chill the basic mixture.

For cold mixtures, the best results are obtained by beating the eggs and sugar with an electric whisk. This helps increase the volume.

The majority of recipes consist of cream, milk, eggs and sugar. You may use whatever cream you wish, but the flavor and texture will vary greatly according to the quality of cream chosen. The higher the percentage of fat, the richer the ice cream, for

example, Heavy Cream contains a minimum of 36% fat, Light Whipping Cream 30%, Light Cream 18%, and Half and Half 10%.

Always maintain the same overall quantity of liquid. For example, the lightest ice cream can be made by using more milk than cream, or by eliminating the cream altogether. You may also use skimmed milk, but the texture of the ice cream will be very different. If you decide not to use the amount of cream called for in a recipe you will need to make up the difference with milk.

The frozen dessert recipe mixture can be kept in the refrigerator for several days. Stir it well before pouring it into the cylinder.

Fill the cylinder no more than half full if using recipes not contained within this Owner's Manual. The mixture increases in volume during preparation.

Alcoholic ingredients slow down the chilling process. Liqueurs should be added only during the final minutes of preparation.

The flavor of sorbets depends largely on the degree of ripeness and sweetness of the fruit and juice used. Taste the fruit before adding it to the recipe. If it is too acidic, add sugar; if it is very ripe, add less sugar or no sugar. Remember that cold reduces sweetness.

Artificial sweeteners can be used in place of sugar. Add the sweetener to the mixture and mix until completely dissolved.

Cooked mixtures must not be poured into the cylinder until they are completely cold.

To sweeten the mixture during preparation, do not add sugar directly into the cylinder (it will not dissolve). Instead, dissolve the sugar in a little water or skimmed milk and pour the resulting syrup (cooled) into the cylinder.

The fruit used in the recipes must always be washed and dried before use. Even when not specified, fruit must always be peeled and seeded.

When using raw eggs, make sure they are fresh.

TROUBLESHOOTING

If the frozen dessert is still not formed after 50 minutes, check the following points before contacting the Consumer Relations Department:

The ingredients must be poured into the Frozen Dessert Maker at room temperature or, preferably, at refrigerator temperature. frozen desserts cannot be made from hot ingredients.

The Removable Cylinder must not be more than half filled if using recipes not contained within this Owner's Manual. If the quantity of ingredients is excessive, the time required to form the frozen dessert increases considerably and the frozen dessert may not be satisfactory.

The compressor is fitted with a safety device. In the event of power failure, or if the Frozen Dessert Maker is turned off and on again for any reason, or operation of the chilling system is interrupted, the Frozen Dessert Maker will automatically shut down for five minutes before turning on again. Operation will not resume, even if the chilling button is pressed down in the On position and the indicator light is on.

We strongly recommend checking all the above points before contacting the Consumer Relations Department. If Consumer Relations does not find a fault, the user will be required to cover the costs of the testing.

RECIPES

ICE CREAM

Banana Pineapple Ice Cream

3 medium ripe bananas, mashed with a fork
1/3 cup crushed pineapple, drained
2/3 cup light corn syrup
1-1/2 cups heavy whipping cream
1 teaspoon vanilla extract

1. Plug the unit in and turn the chilling switch to the on position. Allow the unit to chill for 5 minutes. While cooling prepare mixture.
2. Using an electric mixer, combine all ingredients in a large mixing bowl with a pour spout.
3. At the end of the 5 minute chilling process, turn the Dashing Motor to the on position.
4. Slowly pour mixture through the opening in the Cover.
5. Allow to freeze for 35 minutes or until desired consistency. The Dasher may reverse direction or stop, indicating the ice cream is ready.

Yield: 4-1/2 cups

Berry Cheesecake Ice Cream

8 ounces cream cheese, softened
1 tablespoon lemon juice
1 teaspoon vanilla extract
3/4 cup frozen berries, thawed & drained
1 cup half & half

1. Plug the unit in and turn the chilling switch to the on position. Allow the unit to chill for 5 minutes. While cooling prepare mixture.
2. Using an electric mixer, combine all ingredients in a large mixing bowl with a pour spout.
3. At the end of the 5 minute chilling process, turn the Dashing Motor to the on position.
4. Slowly pour mixture through the opening in the Cover.
5. Allow to freeze for 15 minutes or until desired consistency. The Dasher may reverse direction or stop, indicating the ice cream is ready.

Yield: 3-1/2 cups

Butter Pecan Soft Serve Ice Cream

4.5 to 5.5 ounce box instant vanilla pudding & pie filling mix
3 cups 1% milk
1 cup heavy whipping cream
1/2 cup sugar
1 tablespoon butter flavoring
1 teaspoon vanilla extract
1 cup chopped pecans

1. Plug the unit in and turn the chilling switch to the on position. Allow the unit to chill for 5 minutes. While cooling prepare mixture.
2. Using an electric mixer, combine all ingredients except pecans in a large mixing bowl with a pour spout.
3. At the end of the 5 minute chilling process, turn the Dashing Motor to the on position.
4. Slowly pour the mixture through the opening in the Cover.
5. Allow to freeze for 40-45 minutes or until desired consistency adding the pecans after 30 minutes. The Dasher may reverse direction or stop, indicating the ice cream is ready.

Yield: 4-1/2 cups

Butterscotch Delight Ice Cream

3 to 3.5 ounce box instant butterscotch pudding & pie filling mix
1 cup whole milk
2 cups heavy whipping cream
½ cup sugar
1 tablespoon vanilla extract
1/3 cup toffee bits
1/3 cup semi sweet mini chocolate chips

1. Plug the unit in and turn the chilling switch to the on position. Allow the unit to chill for 5 minutes. While cooling prepare mixture.
2. Using an electric mixer, combine all ingredients except the toffee bits and the chocolate chips in a large mixing bowl with a pour spout.
3. At the end of the 5 minute chilling process, turn the Dashing Motor to the on position.
4. Slowly pour the mixture through the opening in the Cover.
5. Allow to freeze for 25 minutes or until desired consistency, adding the toffee bits and mini chocolate chips after 20 minutes of freezing. The Dasher may reverse direction or stop, indicating the ice cream is ready.

Yield: 4 cups

Chunky Apple Cinnamon Ice Cream

1/3 cup brown sugar
2 teaspoons cinnamon
1/4 teaspoon salt
1-1/2 cups half & half
1 cup 1% milk
1-1/3 cups chunky apple sauce
1 tablespoon lemon juice

1. Plug the unit in and turn the chilling switch to the on position. Allow the unit to chill for 5 minutes. While cooling prepare mixture.
2. Using an electric mixer, combine all ingredients in a large mixing bowl with a pour spout.
3. At the end of the 5 minute chilling process, turn the Dashing Motor to the on position.
4. Slowly pour the mixture through the opening in the Cover.
5. Allow to freeze for 50 minutes or until desired consistency. The Dasher may reverse direction or stop, indicating the ice cream is ready.

Yield: 5 cups

Cinnamon Soft Serve Ice Cream

1/2 cup sugar
1/4 cup light corn syrup
4 teaspoons cinnamon
2 cups half & half
2 cups heavy whipping cream
2 teaspoons vanilla extract

1. Plug the unit in and turn the chilling switch to the on position. Allow the unit to chill for 5 minutes. While cooling prepare mixture.
2. Using an electric mixer, combine all ingredients in a large mixing bowl with a pour spout.
3. At the end of the 5 minute chilling process, turn the Dashing Motor to the on position.
4. Slowly pour mixture through the opening in the Cover.
5. Allow to freeze for 35 minutes or until desired consistency. The Dasher may reverse direction or stop, indicating the ice cream is ready.

Yield: 4-1/2 cups

Cooked Buttermilk Soft Serve Ice Cream

2 cups heavy whipping cream
6 egg yolks
1 cup sugar
2 cups cold buttermilk

1. Pour whipping cream into a sauce pan. Heat to a simmer.
2. Whisk egg yolks and sugar in a bowl. Gradually add to hot cream.
3. Cook over medium heat until mixture is thick enough to coat a metal spoon. Stir in buttermilk.
4. Place in the refrigerator to chill for 4 hours.
5. Plug the unit in and turn the chilling switch to the on position. Allow the unit to chill for 5 minutes.
6. At the end of the 5 minute chilling process, turn the Dashing Motor to the on position.
7. Slowly pour the mixture through the opening in the Cover.
8. Allow to freeze for 25-30 minutes or until desired consistency. The Dasher may reverse direction or stop, indicating the ice cream is ready.

Yield: 4-1/2 cups

Cooked Chocolate Mint Ice Cream

3 egg yolks
5 ounces peppermint patties
1-1/2 cups whole milk
1/2 cup sugar
1 cup heavy whipping cream
1 teaspoon vanilla extract

1. Lightly beat the egg yolks in a bowl. Heat the peppermint patties and milk in a saucepan stirring continually until the chocolates have melted and then remove from heat.
2. Add the egg yolks and sugar and return to the heat. Continue cooking until the mixture thickens and coats a metal spoon.
3. Remove from heat and allow to cool.
4. Add heavy whipping cream and vanilla extract. Place in the refrigerator to chill for 4 hours.
5. Plug the unit in and turn the chilling switch to the on position. Allow the unit to chill for 5 minutes.
6. At the end of the 5 minute chilling process, turn the Dashing Motor to the on position.
7. Slowly pour the mixture through the opening in the Cover.
8. Allow to freeze for 25 minutes or until desired consistency. The Dasher may reverse direction or stop, indicating the ice cream is ready.

Yield: 3 cups

Cooked Grape-Nuts Ice Cream

3 cups heavy whipping cream
6 egg yolks
2/3 cup sugar
1-1/2 teaspoons vanilla extract
1 cup Grape-Nuts

1. Pour whipping cream into a sauce pan. Heat to a simmer.
2. Whisk egg yolks and sugar in a bowl. Gradually add to hot cream.
3. Cook over medium heat until mixture is thick enough to coat a metal spoon.
4. Stir in vanilla extract and place in the refrigerator to chill for 4 hours.
5. Stir in Grape-Nuts.
6. Plug the unit in and turn the chilling switch to the on position. Allow the unit to chill for 5 minutes.
7. At the end of the 5 minute chilling process, turn the Dashing Motor to the on position.
8. Slowly pour the mixture through the opening in the Cover.
9. Allow to freeze for 15 minutes or until desired consistency. The Dasher may reverse direction or stop, indicating the ice cream is ready.

Yield: 4-1/2 cups

Cooked No Fat, No Salt, No Sugar Vanilla Ice Cream

- 1 teaspoon unflavored gelatin
- 2-1/4 cups skim milk
- 1 cup nonfat dry milk
- 4 ounces Egg Beaters
- 15 (1 gram) packets Equal
- 1 tablespoon vanilla extract

1. In a saucepan combine milk and gelatin, allow to stand for 1 minute.
2. Stir mixture over low heat until gelatin dissolves, do not boil.
3. Remove from heat and allow to cool.
4. Using an electric mixer, combine remaining ingredients. Place in the refrigerator to chill for 4 hours.
5. Stir for a few seconds and pour mixture through a strainer to strain out any gelatin lumps.
6. Plug the unit in and turn the chilling switch to the on position. Allow the unit to chill for 5 minutes.
7. At the end of the 5 minute chilling process, turn the Dashing Motor to the on position.
8. Slowly pour the mixture through the opening in the Cover.
9. Allow to freeze for 25 minutes or until desired consistency. The Dasher may reverse direction or stop, indicating the ice cream is ready.

Yield: 3 cups

Cooked Vanilla Ice Cream

- 2 eggs
- 1-1/2 cups whole milk
- 1/2 cup sugar
- 1-1/2 cups heavy whipping cream
- 1 teaspoon vanilla extract

1. Beat the eggs, milk and sugar together. Cook and stir over medium to low heat until mixture thickens and coats a metal spoon.
2. Remove from heat and allow to cool.
3. Add heavy whipping cream and vanilla extract. Place in the refrigerator to chill for 4 hours.
4. Plug the unit in and turn the chilling switch to the on position. Allow the unit to chill for 5 minutes.
5. At the end of the 5 minute chilling process, turn the Dashing Motor to the on position.
6. Slowly pour the mixture through the opening in the Cover.
7. Allow to freeze for 30 minutes or until desired consistency. The Dasher may reverse direction or stop, indicating the ice cream is ready.

Yield: 5 cups

Peppermint Ice Cream

2 ounces Egg Beaters
1/2 cup granulated sugar
1-1/2 cups heavy whipping cream
1-1/4 cups whole milk
1-1/2 teaspoons peppermint flavoring
3/4 cup finely crushed peppermint candy

1. Plug the unit in and turn the chilling switch to the on position. Allow the unit to chill for 5 minutes. While cooling prepare mixture.
2. Using an electric mixer, combine all ingredients except crushed peppermint candy in a large mixing bowl with a pour spout.
3. At the end of the 5 minute chilling process, turn the Dashing Motor to the on position.
4. Slowly pour the mixture through the opening in the Cover.
5. Allow to freeze for 40 minutes or until desired consistency adding the crushed peppermint candy after 30 minutes of freezing. The Dasher may reverse direction or stop, indicating the ice cream is ready.

Yield: 4-1/2 cups

Philadelphia Style Soft Serve Vanilla Ice Cream

1-1/2 cups heavy whipping cream
2 cups half & half
1 tablespoon vanilla extract
1 cup granulated sugar
1/4 teaspoon salt

1. Plug the unit in and turn the chilling switch to the on position. Allow the unit to chill for 5 minutes. While cooling, prepare mixture.
2. Using an electric mixer, combine all ingredients in a large mixing bowl with a pour spout.
3. At the end of the 5 minute chilling process, turn the Dashing Motor to the on position.
4. Slowly pour mixture through the opening in the Cover.
5. Allow to freeze for 40 minutes or until desired consistency. The Dasher may reverse direction or stop, indicating the ice cream is ready.

Yield: 4-1/2 cups

Soy Chocolate Peanut Butter Chip Ice Cream

2 ounces Egg Beaters
1 cup granulated sugar
3-3/4 cups chocolate soy milk
1 tablespoon vanilla extract
1 cup Reese's Peanut Butter Chips

1. Plug the unit in and turn the chilling switch to the on position. Allow the unit to chill for 5 minutes. While cooling prepare mixture.
2. Using an electric mixer, combine all ingredients in a large mixing bowl with a pour spout.
3. At the end of the 5 minute chilling process, turn the Dashing Motor to the on position.
4. Slowly pour the mixture through the opening in the Cover.
5. Allow to freeze for 40 minutes or until desired consistency adding the Reese's Peanut Butter Chips after 30 minutes. The Dasher may reverse direction or stop, indicating the ice cream is ready.

Yield: 4-1/2 cups

Soy Dream Ice Cream

3 cups fresh berries, sliced
3/4 cup soymilk (plain or vanilla)
3 tablespoons honey

1. Plug the unit in and turn the chilling switch to the on position. Allow the unit to chill for 5 minutes. While cooling prepare mixture.
2. Add ingredients to a blender or food processor and blend until smooth and creamy.
3. At the end of the 5 minute chilling process, turn the Dashing Motor to the on position.
4. Slowly pour mixture through the opening in the Cover.
5. Allow to freeze for 30 minutes or until desired consistency. The Dasher may reverse direction or stop, indicating the soy dream is ready.

Yield: 2-1/2 cups

Strawberry Ice Cream

4 ounces Egg Beaters
1/2 cup granulated sugar
1-1/2 cups heavy whipping cream
1-1/2 cups whole milk
1-1/2 teaspoons vanilla extract
3/4 cup frozen strawberries, thawed, drained and mashed with a fork

1. Plug the unit in and turn the chilling switch to the on position. Allow the unit to chill for 5 minutes. While cooling prepare mixture.
2. Using an electric mixer, combine all ingredients in a large mixing bowl with a pour spout.
3. At the end of the 5 minute chilling process, turn the Dashing Motor to the on position.
4. Slowly pour mixture through the opening in the Cover.
5. Allow to freeze for 35 minutes or until desired consistency. The Dasher may reverse direction or stop, indicating the ice cream is ready.

Yield: 5 cups

Sugar Free Pecan Ice Cream

3 cups half & half
4 ounces Egg Beaters
15 (1 gram) packets of Equal
1 tablespoon vanilla extract
1/4 teaspoon almond extract
1/8 teaspoon salt
1/2 cup chopped pecans

1. Plug the unit in and turn the chilling switch to the on position. Allow the unit to chill for 5 minutes. While cooling prepare mixture.
2. Using an electric mixer, combine all ingredients except pecans in a large mixing bowl with a pour spout.
3. At the end of the 5 minute chilling process, turn the Dashing Motor to the on position.
4. Slowly pour the mixture through the opening in the Cover.
5. Allow to freeze for 50 minutes or until desired consistency adding the pecans after 40 minutes of freezing. The Dasher may reverse direction or stop, indicating the ice cream is ready.

Yield: 5-1/2 cups

Tofu Fruit Ice Cream

2 cups pureed fruit of your choice
10 ounces regular tofu, drained & cut in 1 inch chunks
1-1/2 cups sugar

1. Plug the unit in and turn the chilling switch to the on position. Allow the unit to chill for 5 minutes. While cooling prepare mixture.
2. Puree the fruit in a blender or food processor.
3. Add remaining ingredients and blend until smooth.
4. At the end of the 5 minute chilling process, turn the Dashing Motor to the on position.
5. Slowly pour mixture through the opening in the Cover.
6. Allow to freeze for 35 minutes or until desired consistency. The Dasher may reverse direction or stop, indicating the ice cream is ready.

Yield: 3-1/2 cups

Tofu Pineapple Crush Ice Cream

10 ounces soft tofu, drained & cut in 1 inch chunks
2/3 cup soymilk (vanilla or plain)
2 tablespoons lemon juice
1 tablespoon vanilla extract
1/8 teaspoon salt
1 cup brown sugar
20 ounces unsweetened crushed pineapple in natural juices
(drain and set aside 1/3 cup for stirring in before freezing)

1. Plug the unit in and turn the chilling switch to the on position. Allow the unit to chill for 5 minutes. While cooling prepare mixture.
2. Add ingredients to a blender or food processor and blend until smooth and creamy.
3. Stir in 1/3 cup of pineapple that was set aside.
4. At the end of the 5 minute chilling process, turn the Dashing Motor to the on position.
5. Slowly pour mixture through the opening in the Cover.
6. Allow to freeze for 40 minutes or until desired consistency. The Dasher may reverse direction or stop, indicating the ice cream is ready.

Yield: 5 cups

Vanilla Ice Cream

2 ounces Egg Beaters
1/2 cup granulated sugar
1-1/2 cups heavy whipping cream
1-1/2 cups whole milk
1-1/2 teaspoons vanilla extract

1. Plug unit in and turn the chilling switch to the on position. Allow the unit to chill for 5 minutes. While cooling prepare mixture.
2. Using an electric mixer, combine all ingredients in a large mixing bowl with a pour spout.
3. At the end of the 5 minute chilling process, turn the Dashing Motor to the on position.
4. Slowly pour mixture through the opening in the Cover.
5. Allow to freeze for 35 minutes or until desired consistency. The Dasher may reverse direction or stop, indicating the ice cream is ready.

* For flavor variation, add 3/4 cup of any one of the following: M&M's, Toffee Chips, Chocolate Chips, Oreo Cookie Crumbles, Butterfinger crumbled or Reeses Peanut Butter Cup Pieces.

Yield: 5 cups

White Chocolate with Macadamia Nuts Soft Serve Ice Cream

3 to 3.5 ounce box instant white chocolate pudding & pie filling mix
1 cup whole milk
3-1/2 cups half & half
1/2 cup sugar
1 tablespoon vanilla extract
2 ounces white chocolate baking squares, finely grated
1 cup chopped macadamia nuts

1. Plug the unit in and turn the chilling switch to the on position. Allow the unit to chill for 5 minutes. While cooling prepare mixture.
2. Using an electric mixer, combine all ingredients except macadamia nuts in a large mixing bowl with a pour spout.
3. At the end of the 5 minute chilling process, turn the Dashing Motor to the on position.
4. Slowly pour the mixture through the opening in the Cover.
5. Allow to freeze for 45-50 minutes or until desired consistency adding the macadamia nuts after 40 minutes. The Dasher may reverse direction or stop, indicating the ice cream is ready.

Yield: 5 cups

SHERBET

Cantaloupe Sherbet

- 1 medium size cantaloupe—cubed
- 14 ounce can non-fat sweetened condensed milk
- 2 tablespoons honey
- 1 envelope unflavored gelatine

1. Plug the unit in and turn the chilling switch to the on position. Allow the unit to chill for 5 minutes. While cooling prepare mixture.
2. Add ingredients to a blender or food processor and blend until smooth and creamy.
3. At the end of the 5 minute chilling process, turn the Dashing Motor to the on position.
4. Slowly pour mixture through the opening in the Cover.
5. Allow to freeze for 40 minutes or until desired consistency. The Dasher may reverse direction or stop, indicating the sherbet is ready.

Yield: 6 cups

Grape Sherbet

- 4 ounces frozen grape juice concentrate, thawed - cold
- 3 cups 1% or 2% milk
- 2/3 cup sugar
- 1-1/2 teaspoons vanilla extract

1. Plug the unit in and turn the chilling switch to the on position. Allow the unit to chill for 5 minutes. While cooling prepare mixture.
2. Using an electric mixer, combine all ingredients in a large mixing bowl with a pour spout.
3. At the end of the 5 minute chilling process, turn the Dashing Motor to the on position.
4. Slowly pour the mixture through the opening in the Cover.
5. Allow to freeze for 30 minutes or until desired consistency. The Dasher may reverse direction or stop indicating the sherbet is ready.,

Yield: 4-1/2 cups

Mandarin Chocolate Sherbet

4 cups vanilla flavored low-fat soymilk
6 ounce can frozen orange juice concentrate, thawed
1 cup sugar
6 tablespoons unsweetened cocoa powder
1 teaspoon vanilla
1/8 teaspoon salt
1 envelope unflavored gelatin

1. Plug the unit in and turn the chilling switch to the on position. Allow the unit to chill for 5 minutes. While cooling prepare mixture.
2. Add ingredients to a blender and blend until smooth and creamy.
3. At the end of the 5 minute chilling process, turn the Dashing Motor to the on position.
4. Slowly pour mixture through the opening in the Cover.
5. Allow to freeze for 40 minutes or until desired consistency. The Dasher may reverse direction or stop, indicating the sherbet is ready.

Yield: 6 cups

Orange Sherbet

3 ounce box orange gelatin*
3/4 cup sugar
1/8 teaspoon salt
1 cup boiling water
3 cups 1% or 2% milk
1 teaspoon vanilla extract

1. Dissolve gelatin, sugar and salt in the boiling water. Cool to room temperature in a large mixing bowl or pitcher with a pour spout. Do not chill in the refrigerator, as the gelatin will set up.
2. Plug the unit in and turn the chilling switch to the on position. Allow the unit to chill for 5 minutes.
3. Add milk to cooled gelatin mixture stirring constantly.
4. At the end of the 5 minute chilling process, turn the Dashing Motor to the on position.
5. Slowly pour the mixture through the opening in the Cover.
6. Allow to freeze for 50 minutes or until desired consistency. The Dasher may reverse direction or stop, indicating the sherbet is ready.

*Any flavor may be substituted for flavor variation, such as lime or raspberry

Yield: 6 cups

Pineapple Sherbet

16 ounces crushed pineapple—in its own juice
12 ounce can evaporated skim milk
1/3 cup sugar
1 teaspoon vanilla extract

1. Plug the unit in and turn the chilling switch to the on position. Allow the unit to chill for 5 minutes. While cooling prepare mixture.
2. Using an electric mixer, combine all ingredients in a large mixing bowl with a pour spout.
3. At the end of the 5 minute chilling process, turn the Dashing Motor to the on position.
4. Slowly pour mixture through the opening in the Cover.
5. Allow to freeze for 40 minutes or until desired consistency. The Dasher may reverse direction or stop, indicating the sherbet is ready.

Yield 4 cups

Raspberry Sherbet

10 ounces frozen raspberries in syrup, thawed-cold
1-1/2 cups 1% or 2% milk
1/3 cup nonfat dry milk
1/2 cup sugar

1. Puree raspberries and syrup in a blender or food processor with a metal blade until smooth.
2. Pour mixture through a strainer, pressing out as much fruit puree as possible. Discard seeds.
3. Place raspberry puree back in blender or food processor with remaining ingredients and process until well mixed.
4. Plug the unit in and turn the chilling switch to the on position. Allow the unit to chill for 5 minutes.
5. At the end of the 5 minute chilling process, turn the Dashing Motor to the on position.
6. Slowly pour the mixture through the opening in the Cover.
7. Allow to freeze for 40 minutes or until desired consistency. The Dasher may reverse direction or stop, indicating the sherbet is ready.

Yield: 4 cups

Watermelon Sherbet

5 cups watermelon—seeded & cubed
3/4 cup sugar
1 tablespoon lemon juice
1 envelope unflavored gelatin
12 ounce can evaporated skimmed milk

1. Plug the unit in and turn the chilling switch to the on position. Allow the unit to chill for 5 minutes. While cooling prepare mixture.
2. Add ingredients to a blender and blend until smooth and creamy.
3. At the end of the 5 minute chilling process, turn the Dashing Motor to the on position.
4. Slowly pour mixture through the opening in the Cover.
5. Allow to freeze for 40 minutes or until desired consistency. The Dasher may reverse direction or stop, indicating the sherbet is ready.

Yield: 6 cups

SORBET

Apple Sorbet

12 ounce can frozen apple juice concentrate, thawed-cold
2 cups cold water
2 tablespoons lemon juice
1/3 cup light corn syrup

1. Plug the unit in and turn chilling switch to the on position. Allow the unit to chill for 5 minutes. While cooling prepare mixture.
2. Using an electric mixer, combine all ingredients in a large mixing bowl with a pour spout.
3. At the end of the 5 minute chilling process, turn the Dashing Motor to the on position.
4. Slowly pour mixture through the opening in the Cover.
5. Allow to freeze for 35 minutes or until desired consistency. The Dasher may reverse direction or stop, indicating the sorbet is ready.

Yield: 4 cups

Chocolate Sorbet

1-1/4 cups sugar
3 cups water
1/2 cup unsweetened cocoa powder
1/4 teaspoon salt
2 teaspoons vanilla extract

1. Cook sugar in dry saucepan without stirring until it begins to dissolve.
2. Over medium heat, stir occasionally and continue cooking until all sugar is melted and it is just starting to turn a very light caramel brown.
3. Add water—be careful as it will sizzle and splutter. Continue stirring until caramel is dissolved in the water.
4. Whisk in cocoa and salt until all ingredients are dissolved.
5. Transfer to a bowl and cool to room temperature, stirring occasionally. This will take approximately 30 minutes.
6. Stir in vanilla extract.
7. Plug the unit in and turn the chilling switch to the on position. Allow the unit to chill for 5 minutes.
8. At the end of the 5 minute chilling process, turn the Dashing Motor to the on position.
9. Slowly pour mixture through the opening in the Cover.
10. Allow to freeze for 35 minutes or until desired consistency. The Dasher may reverse direction or stop, indicating the sorbet is ready.

Yield: 3-1/2 cups

Green Tea Sorbet

3 cups water
2-1/2 tablespoons good quality green tea
1/2 cup sugar

1. Bring water to a boil, add leaves and remove from heat.
2. Steep for 5 minutes.
3. Add sugar and stir until dissolved
4. Strain through a fine sieve.
5. Chill tea, covered, until cold.
6. Plug the unit in and turn the chilling switch to the on position. Allow the unit to chill for 5 minutes.
7. At the end of the 5 minute chilling process, turn the Dashing Motor to the on position.
8. Slowly pour mixture through the opening in the Cover.
9. Allow to freeze for 30 minutes or until desired consistency. The Dasher may reverse direction or stop, indicating the sorbet is ready.

Yield: 3 cups

Orange Sorbet

- 2 cups fresh orange juice
- 1 tablespoon lemon juice
- 1 cup water
- 1 cup sugar

1. Plug the unit in and turn the chilling switch to the on position. Allow the unit to chill for 5 minutes. While cooling prepare mixture.
2. Using an electric mixer, combine all ingredients in a large mixing bowl with a pour spout.
3. At the end of the 5 minute chilling process, turn the Dashing Motor to the on position.
4. Slowly pour mixture through the opening in the Cover.
5. Allow to freeze for 30 minutes or until desired consistency. The Dasher may reverse direction or stop, indicating the sorbet is ready.

Yield: 4 cups

Pineapple Sorbet

- 2-1/4 cups cold water
- 1-1/4 cups sugar
- 6 ounces frozen pineapple concentrate, thawed-cold
- 2 teaspoons lemon juice
- 2 teaspoons vanilla extract

1. Using a saucepan, bring the water and sugar to a boil. Allow to boil for 2 minutes.
2. Remove from heat and allow to cool.
3. Add remaining ingredients and mix well. Place in the refrigerator to chill for 4 hours.
4. Plug the unit in and turn the chilling switch to the on position. Allow the unit to chill for 5 minutes.
5. At the end of the 5 minute chilling process, turn the Dashing Motor to the on position.
6. Slowly pour the mixture through the opening in the Cover.
7. Allow to freeze for 50 minutes or until desired consistency. The Dasher may reverse direction or stop, indicating the sorbet is ready.

Yield: 5 cups

Plum Sorbet

3/4 pound plums, rinsed pitted sliced with peeling
1 cup fresh orange juice
3 tablespoons sugar
1 tablespoon orange zest

1. Plug the unit in and turn the chilling switch to the on position. Allow the unit to chill for 5 minutes. While cooling prepare mixture.
2. Add ingredients to a blender or food processor and blend until smooth and creamy.
3. At the end of the 5 minute chilling process, turn the Dashing Motor to the on position.
4. Slowly pour mixture through the opening in the Cover.
5. Allow to freeze for 30 minutes or until desired consistency. The Dasher may reverse direction or stop, indicating the sorbet is ready.

Yield: 3 cups

YOGURT

Blackberry Frozen Yogurt

1/3 cup sugar
1/3 cup water
16 ounces frozen blackberries, unsweetened-thawed-cold or 2 cups fresh blackberries, stemmed and washed
1 cup 1% milk
1 cup plain yogurt
1/2 cup nonfat dry milk

1. In a saucepan, combine sugar and water. Bring to a boil; lower heat and cook for 3 to 4 minutes to dissolve sugar. Remove from heat and allow to cool slightly.
2. In a blender or food process fitted with a metal blade, puree berries. Strain and push through fruit puree. When finished, discard seeds. Pour cooled water mixture through strainer in order to speed up straining process.
3. Combine remaining ingredients using an electric mixer until smooth and creamy. Chill in refrigerator for 4 hours.
4. Plug the unit in and turn the chilling switch to the on position. Allow the unit to chill for 5 minutes.
5. At the end of the 5 minute chilling process, turn the Dashing Motor to the on position.
6. Slowly pour the mixture through the opening in the Cover.
7. Allow to freeze for 40 minutes or until desired consistency. The Dasher may reverse direction or stop, indicating the yogurt is ready.

Yield: 5 cups

Low Fat Raspberry Frozen Yogurt

1 cup fresh or frozen raspberries, unsweetened-thawed-cold
1/4 cup warm water
1 teaspoon unflavored gelatin
12 (1 gram) packets Equal
1 cup plain low fat yogurt
2 ounces Egg Beaters
1/3 cup cold water
1/3 cup nonfat dry milk

1. In a blender or food process fitted with a metal blade, puree berries. Strain discarding seeds.
2. In a cup combine water with gelatin; let stand 1 minute. Place in the microwave and heat for 30 seconds stir to make sure the gelatin is dissolved. Cool slightly.
3. Combine pureed berries with Equal and dissolved gelatin. Stir in yogurt.
4. In a small bowl, combine Egg Beaters with 1/3 cup water and dry milk then add raspberry mixture. Chill in refrigerator for 4 hours.
5. Plug the unit in and turn the chilling switch to the on position. Allow the unit to chill for 5 minutes.
6. At the end of the 5 minute chilling process, turn the Dashing Motor to the on position.
7. Slowly pour the mixture through the opening in the Cover.
8. Allow to freeze for 35 minutes or until desired consistency. The Dasher may reverse direction or stop, indicating the yogurt is ready.

Yield: 3-1/2 cups

Vanilla Frozen Yogurt

1 cup plain yogurt
1 cup half & half
1 cup whole milk
2/3 cup sugar
4 ounces Egg Beaters
1 tablespoon vanilla extract
1/4 cup malted milk powder
1/8 teaspoon salt

1. Plug the unit in and turn the chilling switch to the on position. Allow the unit to chill for 5 minutes. While cooling prepare mixture.
2. Using an electric mixer, combine all ingredients in a large mixing bowl with a pour spout.
3. At the end of the 5 minute chilling process, turn the Dashing Motor to the on position.
4. Slowly pour the mixture through the opening in the Cover.
5. Allow to freeze for 40 minutes or until desired consistency. The Dasher may reverse direction or stop, indicating the yogurt is ready.

Yield: 5 cups

ITALIAN ICE

Espresso Italian Ice

3 tablespoons instant coffee granules
3-2/3 cups boiling water
3/4 cup sugar
1 teaspoon vanilla extract

1. Dissolve coffee and sugar in the boiling water.
2. Stir in vanilla extract.
3. Place in refrigerator to chill for 4 hours.
4. Plug the unit in and turn the chilling switch to the on position. Allow the unit to chill for 5 minutes.
5. At the end of the 5 minute chilling process, turn the Dashing Motor to the on position.
6. Slowly pour the mixture through the opening in the Cover.
7. Allow to freeze for 20 minutes or until desired consistency. The Dasher may reverse direction or stop, indicating the Italian ice is ready.

Yield: 3 cups

Gazpacho Italian Ice

2 cups spicy tomato juice
1 large peeled seeded chopped fresh ripe tomato
1 cup peeled seeded chopped cucumber
1/4 cup finely minced red onion
1/4 cup finely minced peeled green or red pepper
4 ounces Egg Beaters
2 tablespoons sugar
2 tablespoons olive oil
2 tablespoons red wine vinegar
1/4 teaspoon salt
1/8 teaspoon pepper
2 drops of chipotle Tabasco sauce

1. Plug the unit in and turn the chilling switch to the on position. Allow the unit to chill for 5 minutes. While cooling prepare mixture.
2. Using a blender, combine all ingredients and pulse 5 or 6 times to thoroughly mix ingredients.
3. At the end of the 5 minute chilling process, turn the Dashing Motor to the on position.
4. Slowly pour the mixture through the opening in the Cover.
5. Allow to freeze for 40 minutes or until desired consistency adding. The Dasher may reverse direction or stop, indicating the Italian ice is ready.

Yield: 4 cups

GELATO

Black Walnut Gelato

- 2 cups half & half
- 4 ounces Egg Beaters
- 2/3 cup dark corn syrup
- 3 tablespoons vanilla extract
- 1/8 teaspoon salt
- 1 cup chopped black walnuts

1. Plug the unit in and turn the chilling switch to the on position. Allow the unit to chill for 5 minutes. While cooling prepare mixture.
2. Using an electric mixer, combine all ingredients except walnuts in a large mixing bowl with a pour spout.
3. At the end of the 5 minute chilling process, turn the Dashing Motor to the on position.
4. Slowly pour the mixture through the opening in the Cover.
5. Allow to freeze for 50 minutes or until desired consistency adding the walnuts after 40 minutes of freezing. The Dasher may reverse direction or stop, indicating the gelato is ready.

Yield: 4 cups

BEVERAGES

Apple Rum Ice Cream Shake

- 1/3 cup packed dark brown sugar
- 1/4 teaspoon salt
- 2 cups half & half
- 1-1/3 cups chunky apple sauce
- 1 tablespoon lemon juice
- 2 teaspoons rum extract

1. Plug the unit in and turn the chilling switch to the on position. Allow the unit to chill for 5 minutes. While cooling prepare mixture.
2. Using an electric mixer, combine all ingredients in a large mixing bowl with a pour spout.
3. At the end of the 5 minute chilling process, turn the Dashing Motor to the on position.
4. Slowly pour the mixture through the opening in the Cover.
5. Allow to freeze for 50 minutes or until desired consistency. The Dasher may reverse direction or stop, indicating the shake is ready.

Yield: 5-1/2 cups

Banana Ice Cream Shake

14 ounce can sweetened condensed milk
2 tablespoons vanilla extract
1 cup half & half
2 cups heavy whipping cream
1 cup mashed banana

1. Plug the unit in and turn the chilling switch to the on position. Allow the unit to chill for 5 minutes. While cooling prepare mixture.
2. Using an electric mixer, combine all ingredients in a large mixing bowl with a pour spout.
3. At the end of the 5 minute chilling process, turn the Dashing Motor to the on position.
4. Slowly pour mixture through the opening in the Cover.
5. Allow to freeze for 30 minutes or until desired consistency. The Dasher may reverse direction or stop, indicating the shake is ready.

Yield: 5 cups

Fresh Strawberry Frozen Daiquiri

2 cups cold water
1/4 cup lime juice
20 ounces frozen strawberries in syrup, thawed - cold
3 ounces rum

1. Plug the unit in and turn the chilling switch to the on position. Allow the unit to chill for 5 minutes. While cooling prepare mixture.
2. Using an electric mixer, combine all ingredients except rum in large mixing bowl with a pour spout.
3. At the end of the 5 minute chilling process, turn the Dashing Motor to the on position.
4. Slowly pour the mixture through the opening in the Cover.
5. Allow to freeze for 40 minutes or until desired consistency adding the rum after 15 minutes of freezing. The Dasher may reverse direction or stop, indicating the daiquiri is ready.

Yield: 4-1/2 cups

Frozen Daiquiri

3 cups limeade
3 ounces rum

1. Plug the unit in and turn the chilling switch to the on position. Allow the unit to chill for 5 minutes.
2. At the end of the 5 minute chilling process, turn the Dashing Motor to the on position.
3. Slowly pour the limeade through the opening in the Cover.
4. Allow to freeze for 40 minutes or until desired consistency adding the rum after 15 minutes of freezing. The Dasher may reverse direction or stop, indicating the daiquiri is ready.

Yield: 3 cups

Frozen Margaritas

1-1/2 cups cold water
1-1/2 cups margarita mix, non-alcoholic-cold
1/4 cup tequila

1. Plug the unit in and turn the chilling switch to the on position. Allow the unit to chill for 5 minutes. While cooling prepare mixture.
2. Combine all ingredients except tequila in large mixing bowl with a pour spout.
3. At the end of the 5 minute chilling process, turn the Dashing Motor to the on position.
4. Slowly pour the mixture through the opening in the Cover.
5. Allow to freeze for 35 minutes or until desired consistency adding the tequila after 15 minutes of freezing. The Dasher may reverse direction or stop, indicating the margarita is ready.

Yield: 3 cups

Frozen Pina Coladas

2 cups pina colada mix, non-alcoholic-cold
1-1/3 cups cold water
1/2 cup rum

1. Plug the unit in and turn the chilling switch to the on position. Allow the unit to chill for 5 minutes. While cooling prepare mixture.
2. Combine all ingredients except rum in large mixing bowl with a pour spout.
3. At the end of the 5 minute chilling process, turn the Dashing Motor to the on position.
4. Slowly pour the mixture through the opening in the Cover.
5. Allow to freeze for 40 minutes or until desired consistency adding the rum after 15 minutes of freezing. The Dasher may reverse direction or stop, indicating the pina colada is ready.

Yield: 4 cups

Frozen Strawberry Daiquiri

2 cups strawberry daiquiri mix, non-alcoholic-cold
1-1/3 cups cold water
1/2 cup rum

1. Plug the unit in and turn the chilling switch to the on position. Allow the unit to chill for 5 minutes. While cooling prepare mixture.
2. Combine all ingredients except rum in large mixing bowl with a pour spout.
3. At the end of the 5 minute chilling process, turn the Dashing Motor to the on position.
4. Slowly pour the mixture through the opening in the Cover.
5. Allow to freeze for 40 minutes or until desired consistency adding the rum after 15 minutes of freezing. The Dasher may reverse direction or stop, indicating the daiquiri is ready.

Yield: 4 cups

Grape Slushie

8 ounces frozen grape juice concentrate, thawed - cold
1-3/4 cups cold water
1-1/3 cups whole milk
1/4 cup granulated sugar
2 teaspoons vanilla extract

1. Plug the unit in and turn the chilling switch to the on position. Allow the unit to chill for 5 minutes. While cooling prepare mixture.
2. Using an electric mixer, combine all ingredients in a large mixing bowl with a pour spout.
3. At the end of the 5 minute chilling process, turn the dashing motor to the on position.
4. Slowly pour mixture through the opening in the Cover.
5. Allow to freeze for 35 minutes or until desired consistency. The Dasher may reverse direction or stop, indicating the slushie is ready.

Yield: 4 cups

Holiday Eggnog

4 cups eggnog
4 teaspoons brandy extract
3/4 teaspoon nutmeg

1. Plug the unit in and turn the chilling switch to the on position. Allow the unit to chill for 5 minutes. While cooling prepare mixture.
2. Using an electric mixer, combine all ingredients in a large mixing bowl with a pour spout.
3. At the end of the 5 minute chilling process, turn the Dashing Motor to the on position.
4. Slowly pour the mixture through the opening in the Cover.
5. Allow to freeze for 25 minutes or until desired consistency. The Dasher may reverse direction or stop, indicating the Eggnog is ready.

Yield: 4 cups

Lemon Slushie

8 ounces frozen lemonade concentrate, thawed - cold
1-3/4 cup cold water
1-1/3 cups whole milk
1 cup granulated sugar
1-1/2 teaspoons vanilla extract

1. Plug the unit in and turn the chilling switch to the on position. Allow the unit to chill for 5 minutes. While cooling prepare mixture.
2. Using an electric mixer, combine all ingredients in a large mixing bowl with a pour spout.
3. At the end of the 5 minute chilling process, turn the Dashing Motor to the on position.
4. Slowly pour the mixture through the opening in the Cover.
5. Allow to freeze for 40 minutes or until desired consistency. The Dasher may reverse direction or stop, indicating the slushie is ready.

Yield: 4 cups

Lime Frosty

3 cups whole milk
6 ounces frozen limeade concentrate, thawed - cold
1/2 cup sugar
2 drops green food coloring

1. Plug the unit in and turn the chilling switch to the on position. Allow the unit to chill for 5 minutes. While cooling prepare mixture.
2. Using an electric mixer, combine all ingredients in a large mixing bowl with a pour spout.
3. At the end of the 5 minute chilling process, turn the Dashing Motor to the on position.
4. Slowly pour the mixture through the opening in the Cover.
5. Allow to freeze for 35 minutes or until desired consistency. The Dasher may reverse direction or stop, indicating the frosty is ready.

Yield: 5 cups

Maraschino Cherry Shake

10 ounces maraschino cherries in juice
2 cups heavy whipping cream
1/2 cup whole milk
1/2 cup sugar
1 teaspoon vanilla extract

1. Drain and reserve juice from cherries; chop cherries
2. Plug the unit in and turn the chilling switch to the on position. Allow the unit to chill for 5 minutes. While cooling prepare mixture.
3. Using an electric mixer, combine remaining ingredients with cherry juice in a large mixing bowl with a pour spout.
4. At the end of the 5 minute chilling process, turn the Dashing Motor to the on position.
5. Slowly pour the mixture through the opening in the Cover.
6. Allow to freeze for 40 minutes or until desired consistency adding the chopped cherries at the added ingredient beep when 2 minutes are remaining. The Dasher may reverse direction or stop, indicating the shake is ready.

Yield: 5-1/2 cups

Orange Slush

8 ounces frozen orange juice concentrate*, thawed - cold
2 cups cold water
1-1/3 cups whole milk
2/3 cup granulated sugar
1-1/2 teaspoons vanilla extract

1. Plug the unit in and turn the chilling switch to the on position. Allow the unit to chill for 5 minutes. While cooling prepare mixture.
2. Using an electric mixer, combine all ingredients in a large mixing bowl with a pour spout.
3. At the end of the 5 minute chilling process, turn the Dashing Motor to the on position.
4. Slowly pour mixture through the opening in the Cover.
5. Allow to freeze for 35 minutes or until desired consistency. The Dasher may reverse direction or stop, indicating the slush is ready.

* any other flavor for variation, such as lemon or lime

Yield: 4-1/2 cups

Oreo Cookies'n Cream Ice Cream Shake

4 to 4.5 ounce box instant Oreo Cookies'n Cream pudding & pie filling mix

1-1/2 cups whole milk

2 cups heavy whipping cream

1/2 cup sugar

1 tablespoon vanilla extract

1. Plug the unit in and turn the chilling switch to the on position. Allow the unit to chill for 5 minutes. While cooling prepare mixture.
2. Using an electric mixer, combine all ingredients in a large mixing bowl with a pour spout.
3. At the end of the 5 minute chilling process, turn the Dashing Motor to the on position.
4. Slowly pour the mixture through the opening in the Cover.
5. Allow to freeze for 25 minutes or until desired consistency. The Dasher may reverse direction or stop indicating the shake is ready.

Yield: 4 cups

Peach Shake

2 cups half & half

3/4 cup sugar

1/4 cup non-fat dry milk

15 ounces canned peach chunks, drained

1 tablespoon lemon juice

2 teaspoons vanilla extract

1. Combine half & half, sugar and dry milk in a blender or food processor and process until smooth.
2. Add peaches and remaining ingredients then process until smooth.
3. Plug the unit in and turn the chilling switch to the on position. Allow the unit to chill for 5 minutes.
4. At the end of the 5 minute chilling process, turn the Dashing Motor to the on position.
5. Slowly pour the mixture through the opening in the Cover.
6. Allow to freeze for 25 minutes or until desired consistency. The Dasher may reverse direction or stop. indicating the shake is ready.

Yield: 4 cups

Strawberry Ice Cream Malt

10 ounces frozen strawberries with sugar, thawed - cold
1 cup whole milk
2 cups half & half
1-1/2 teaspoons vanilla extract
2 teaspoons strawberry flavoring
1/4 cup malted milk powder

1. Plug the unit in and turn the chilling switch to the on position. Allow the unit to chill for 5 minutes. While cooling prepare mixture.
2. Puree strawberries with whole milk in a blender until smooth.
3. Add the remaining ingredients to the blender and process until well mixed.
4. At the end of the 5 minute chilling process, turn the Dashing Motor to the on position.
5. Slowly pour the mixture through the opening in the Cover.
6. Allow to freeze for 40 minutes or until desired consistency. The Dasher may reverse direction or stop, indicating the malt is ready.

Yield: 4-1/2 cups

Tropical Smoothie

4 cups V8 Splash Smoothies Tropical Colada
8 ounce can crushed pineapple, drained
1/2 teaspoon pineapple flavoring
1/2 teaspoon almond extract
1/2 teaspoon coconut extract
1/2 teaspoon banana extract

1. Plug the unit in and turn the chilling switch to the on position. Allow the unit to chill for 5 minutes. While cooling prepare mixture.
2. Using an electric mixer, combine all ingredients in a large mixing bowl with a pour spout.
3. At the end of the 5 minute chilling process, turn the Dashing Motor to the on position.
4. Slowly pour the mixture through the opening in the Cover.
5. Allow to freeze for 35 minutes or until desired consistency. The Dasher may reverse direction or stop, indicating the smoothie is ready.

Yield: 4 cups

Vanilla Bean Ice Cream Shake

14 ounces can sweetened condensed milk
Seeds from a 2-inch vanilla bean halved lengthwise & scraped
2 cups half & half
2 cups whipping cream

1. Plug the unit in and turn the chilling switch to the on position. Allow the unit to chill for 5 minutes. While cooling prepare mixture.
2. Using an electric mixer, combine all ingredients in a large mixing bowl with a pour spout.
3. At the end of the 5 minute chilling process, turn the Dashing Motor to the on position.
4. Slowly pour mixture through the opening in the Cover.
5. Allow to freeze for 40 minutes or until desired consistency. The Dasher may reverse direction or stop, indicating the shake is ready.

Yield: 5-1/2 cups

White Chocolate with Macadamia Nuts Soft Serve Ice Cream

3 to 3.5 ounce box instant white chocolate pudding and pie filling mix
1 cup whole milk
3-1/2 cups half & half
1/2 cup sugar
1 tablespoon vanilla extract
2 ounces white chocolate baking squares, finely grated
1 cup chopped macadamia nuts

1. Plug the unit in and turn the chilling switch to the on position. Allow the unit to chill for 5 minutes. While cooling prepare mixture.
2. Using an electric mixer, combine all ingredients except macadamia nuts in a large mixing bowl with a pour spout.
3. At the end of the 5 minute chilling process, turn the Dashing Motor to the on position.
4. Slowly pour the mixture through the opening in the Cover.
5. Allow to freeze for 45-50 minutes or until desired consistency adding the macadamia nuts after 40 minutes. The Dasher may reverse direction or stop, indicating the ice cream is ready.

Yield: 5-1/2 cups

NOTES:

Chocolate Strawberry Banana Malt

2 cups half and half

1/4 cups sugar

14 ounce can sweetened condensed milk

1/4 cup chocolate malted milk

11 to 12 ounce can strawberry banana nectar from concentrate

1 teaspoon banana extract

1 teaspoon strawberry extract

1/8 teaspoon salt

1. Plug the unit in and turn the chilling switch to the on position. Allow the unit to chill for 5 minutes. While cooling prepare mixture.
2. Using an electric mixer, combine all ingredients in a large mixing bowl with a pour spout.
3. At the end of the 5 minute chilling process, turn the Dashing Motor to the on position.
4. Slowly pour the mixture through the opening in the Cover.
5. Allow to freeze for 40 minutes or until desired consistency. The Dasher may reverse direction or stop, indicating the malt is ready.

Yield: 4-1/2 cups